



# 265 CC Owner's Manual

Model Year 2026



# Table of Contents

- Cobia 265 CC Specifications .....2**
- Designated Occupancy Position.....2**
- 265 CC Deck Layout.....3**
- Pre-Operation Checklist .....4**
- Maintenance & Cleaning .....5**
- Engine Break-In Period.....7**
- Helm & Command Link Gauges.....8**
- Fuel-Water Separator & Drain .....9**
- Bilge .....10**
- Systems .....12**
- Ladder & Props .....16**
- Fuel System .....17**
- Self-Bailing Cockpit & Livewell.....17**
- Rod Storage & Fish Lockers .....19**
- Anchor Locker.....20**
- Table Lift .....20**
- Trim Tabs.....21**
- Water System .....22**
- Battery Switch and Main Distribution Panel.....23**
- Seating .....24**
- Standard Features.....26**
- Optional Features .....33**
- Location and Reordering of Warning Labels .....34**
- Location and Reordering of Warning Labels .....35**
- Cobia 265 CC Hull Wire Harness.....36**
- Cobia 265 CC Fwd Deck Wire Harness .....37**
- Cobia 265 CC Aft Deck Wire Harness.....38**
- Warranty .....42**



**Maverick Boat Group**

3207 Industrial 29th St. • Fort Pierce, Florida 34946  
(772)-465-0631 • [cobiaboats.com](http://cobiaboats.com)

# Cobia 265 CC Specifications

L.O.A.....	26' 05"
BEAM.....	9' 05"
DRAFT.....	21"
WEIGHT W ENGINE.....	6,450 LBS.
FUEL CAPACITY.....	161 GAL.
DEADRISE @ TRANSOM.....	21 DEG.
MAXIMUM H.P.....	500
TRANSOM HEIGHT.....	25" TWINS

## Designated Occupancy Position

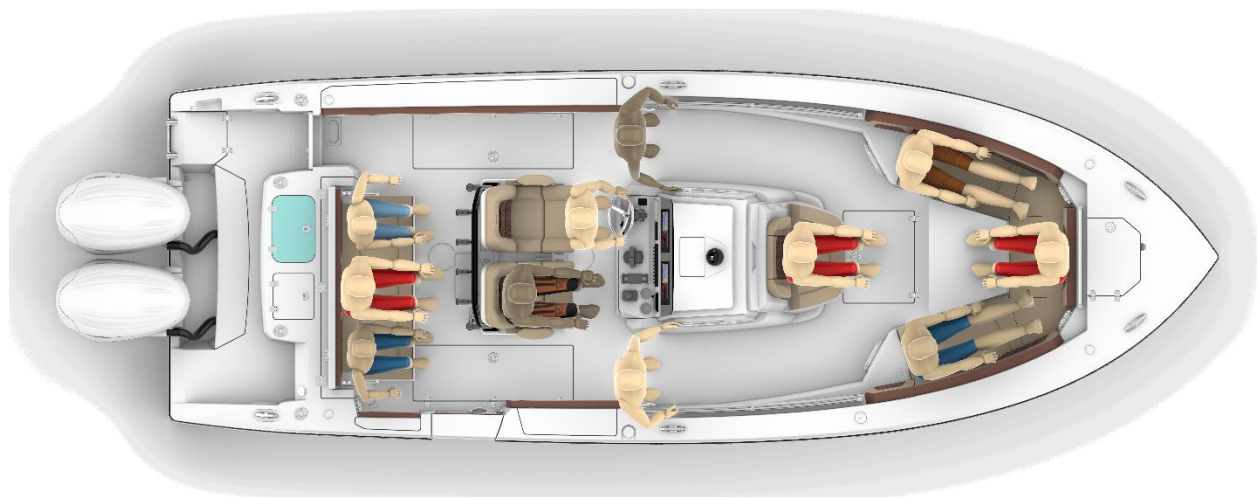

**Maverick Boat Group**

3207 Industrial 29th St. • Fort Pierce, Florida 34946  
(772)-465-0631 • [cobiaboats.com](http://cobiaboats.com)

# 265 CC Deck Layout

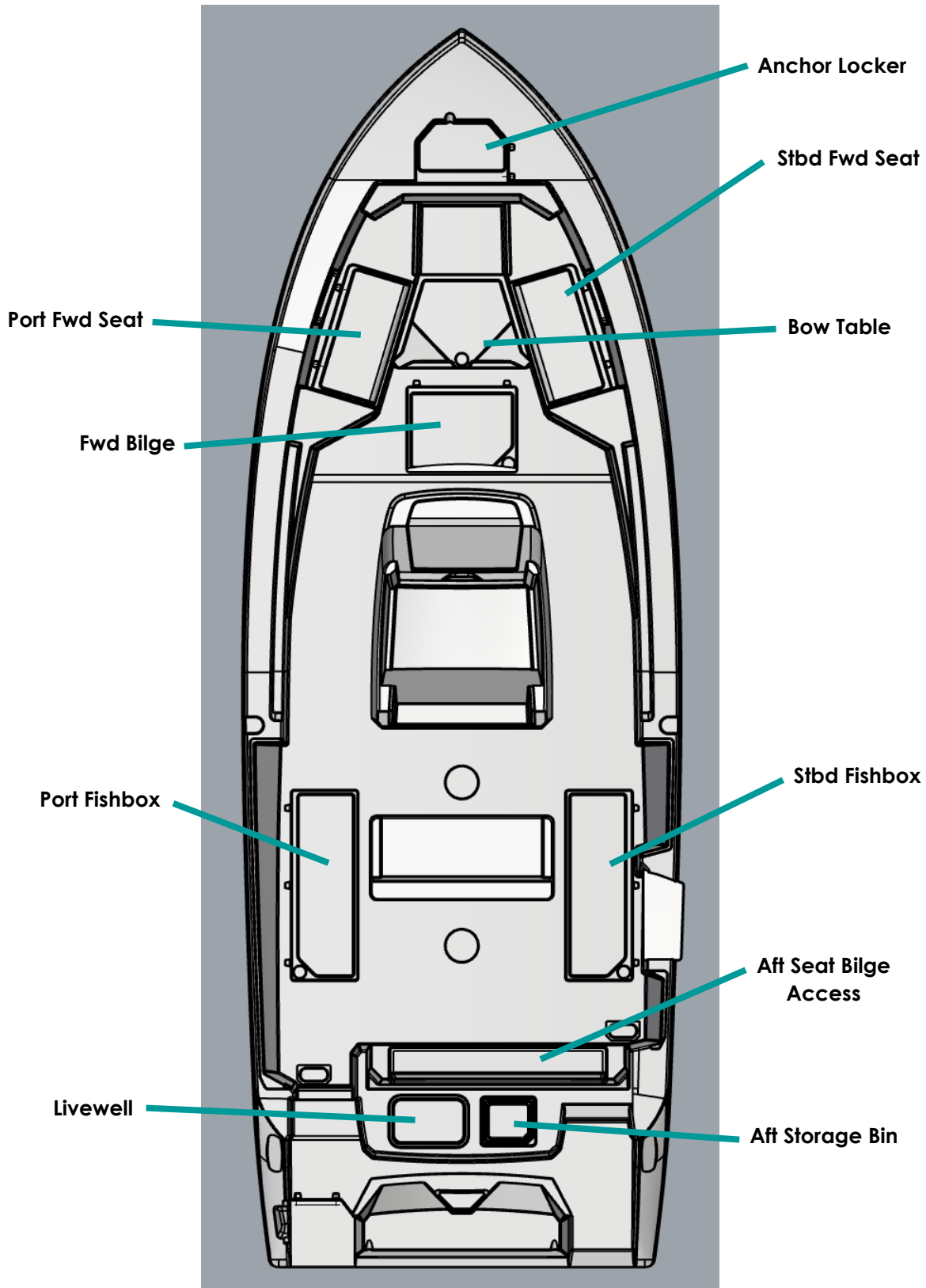

**Maverick Boat Group**

3207 Industrial 29th St. • Fort Pierce, Florida 34946  
(772)-465-0631 • [cobiaboats.com](http://cobiaboats.com)

# Pre-Operation Checklist

We recommend you print this document and store it at the helm station.

## Boating Safety Checklist

**MUST HAVE ITEMS**  
As Required By Regulation

**Personal Flotation Devices (Life Jackets)**

Type I, II, or V for each person onboard (Wearable)

One Type IV (Throwable)  
Not Required on Non-Powered boats under 16'

**Fire Extinguishers**

Choose One	Boats w/out Fixed System	Boats w/ Fixed System
<input type="checkbox"/> Boats <26'	1 Size BI	1 Size BI - OR - Fixed System
<input type="checkbox"/> Boats 26 - <40'	2 Size BI*	2 Size BI - OR - Fixed System + 1 Size BI
<input type="checkbox"/> Boats 40 - 65'	3 Size BI*	3 Size BI - OR - Fixed system + 2 Size BI*

\* One Size BI may be substituted for Two Size BI Extinguishers

**Visual Distress Signals (VDS)**

Choose One

Combination Day/Night VDS (Flares or Flare Gun)

Daytime VDS (Flags, Smoke Signal) AND Nighttime VDS (Automated SOS Light)

**Sound Signals**

Horn or Whistle

Bell (Not required for vessels under 12m)

**Ventilation (Boats with Gasoline Systems)**

Natural Ventilation

Powered Ventilation

**Backfire Flame Control**

Backfire Flame Arrestor (Gasoline Engines except outboards)

## Boating Safety Checklist

Recommended Items

Items in Red May be Required in Some States

**Boats on Inland Waters**  
Everything on Required List PLUS:

**First Aid Kit**

**Boating Safety Education/Certificate**

**Anchor with Sufficient Line**

**Watersports Flag (Skier Down/Diver Down Flag)**

Bailing Device

Sun Protection

Alternate Propulsion (Paddles, Oars)

**Boats on Nearshore Waters**  
Everything Above PLUS:

Extra Food & Water

GPS/Chartplotter

Float Plan

Depth Finder

Compass

Charts

VHF Radio

Spare Tool Kit

**Boats on Offshore Waters**  
Everything Above PLUS:

EPIRB

Life Raft

Man-Overboard Recovery Gear

AIS

Sea Drogue

Searchlight

Safety Knife

List of CPR Instruction

Weather Information System

Radar

Weather Information System

Radio Reflector

Radio Direction Finder

Shore Landing Craft (Tender)

Long Range Communications Gear

**Boats on River Waters**  
Everything on Required List Plus:

Throw Bag

Helmet

**Miscellaneous Items**  
Other Items That May be Recommended:

Heaving Line

Strobe Light

Spare Keys

Carbon Monoxide Detector

Boat Hook/Pole

Extra Clothing

Spare Propeller

Marine Hardware

Extra Engine Oil

Masks & Fins (For Clearing Props)

Handheld Lead-line

Storm Sails

Scan here to download the ABYC Boating Safety Checklist App  
[abycinc.org/mobileapps](http://abycinc.org/mobileapps)





**Maverick Boat Group**

3207 Industrial 29th St. • Fort Pierce, Florida 34946

(772)-465-0631 • [cobiaboats.com](http://cobiaboats.com)

# Maintenance & Cleaning

## Maintenance

Cobia advises owners that maintenance and repairs should be performed at an authorized Cobia Dealer. The following information is general in nature and should not be considered a repair manual or guidelines set forth by Maverick Boat Group.

## Cleaning

Each Cobia boat is constructed using the finest materials and components available. However, no material is immune to the ravages of the saltwater environment. After each use, your boat should be thoroughly washed using fresh water. To avoid water spots, dry your vessel using a soft cloth. A fiberglass wax may be used to preserve the luster of the hull.

Thorough and routine cleanings of your stainless fittings are required to maintain their appearance. After each use of your boat, clean stainless fittings using fresh water and a mild soap. Dry fittings completely. A wax or polish may be applied after cleaning. Any rust must be removed as soon as possible to prevent irreversible damage to your vessel and/or its components. A light coat of lubricant on metal railing, screws and electrical connections will help prevent electrolysis. The same holds true for your trailer. Refer to page 38 for upholstery care and cleaning instructions.



### Maverick Boat Group

3207 Industrial 29th St. • Fort Pierce, Florida 34946  
(772)-465-0631 • [cobiaboats.com](http://cobiaboats.com)

### **Aquatic Invasive Species (AIS)**

Aquatic invasive species (AIS) are plants and animals that occur in waters in which they are not native and whose introduction causes or is likely to cause economic or environmental damage or harm to human health. AIS have a negative impact on the waterway, its native species, and recreational and commercial uses of the waterway.

As responsible boaters and citizens, each boat owner should do their part to prevent the spread of these aquatic hitchhikers. In many cases, it is also required by law. Check local regulations for any waterway where you will boat.

After each boating trip, follow these three simple steps before you leave the water access to stop the spread of AIS: Clean, Drain, and Dry. This is the boater's way to help protect the environment from the damage that AIS can cause.



## **STOP AQUATIC HITCHHIKERS!**

Be A Good Steward. Clean. Drain. Dry.

[StopAquaticHitchhikers.org](http://StopAquaticHitchhikers.org)

### **Clean**

Inspect and remove all aquatic plants, animals, mud, and debris from the boat, engine, trailer, anchor, and any watersports equipment.

Rinse, scrub or wash, as appropriate, away from storm drains, ditches, or waterways.

Rinse watercraft, trailer, and equipment with hot water, when possible.

Flush motor according to owner's manual.

### **Drain**

Completely drain all water from the boat and its compartments, including but not limited to the bilge, wells, lockers, ballast tanks or bags, bait containers, engines, and outdrives.

### **Dry**

Allow the boat to completely dry before visiting any other bodies of water.

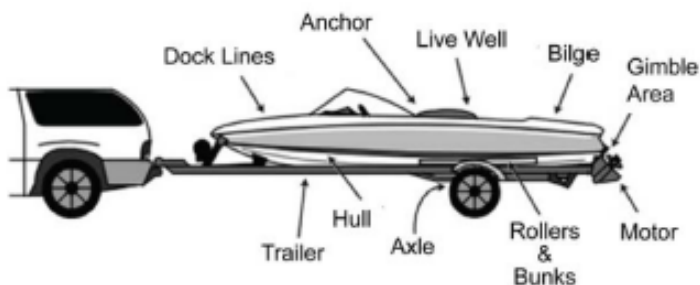

*NOTE: Some localities may require inspection or decontamination before and/or after launching. Check state and local laws and regulations for requirements prior to traveling to go boating.*



### **Maverick Boat Group**

3207 Industrial 29th St. • Fort Pierce, Florida 34946

(772)-465-0631 • [cobiaboats.com](http://cobiaboats.com)

# Engine Break-In Period

## Engine Break-In Period

New engines require a period of break-in to allow the surfaces of the moving parts to mate evenly. Different engines require different break-in periods and methods. For instructions on break-in methods, refer to your Yamaha Engine Owner's Manual for the correct break-in procedures and times for your model engines.

## Engine Stop Switch

If activated, the spring-loaded engine stop switch will automatically shut down the engine during emergency situations to prevent uncontrolled or unattended operation. Certain emergency conditions (e.g., turbulent water, wakes, unanticipated movement) may impair a person's ability to operate the craft safely. The switch, located on the helm, must have the safety lanyard attached at its base. This activates the protective shutdown circuitry.

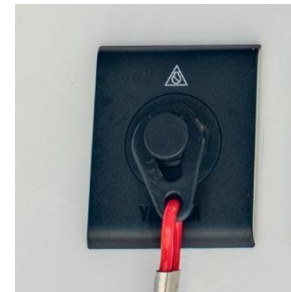

Engine Stop Switch

Securely attach the other end of the lanyard to the operator of the boat. If the operator moves, falls or is at an unsafe distance from the steering wheel, tension on the lanyard will pull it from the switch. When the lanyard is removed, the engine stop switch is released and automatic engine shutdown occurs.



### **DANGER:**

An engine stop switch system that is not used or does not function properly can cause death or serious injury. DO NOT operate the boat if the engine stop switch system does not function properly. Go to a Cobia Dealer to have this resolved immediately.

**The lanyard should be securely attached to the boat operator at all times that the engine is on.**

# Helm & Command Link Gauges

## Switch Panel & Helm

At the helm of your Cobia, you have a main switch panel, which is located above and starboard of the steering wheel. This panel controls your lights, horn, accessories, livewell, and your bilge. The nav light switch is set up so that one direction will light both the nav lights and anchor light, and the other will only light the anchor light. This switch will also light up the compass and switch the JL to night mode. To the right of the steering wheel you have your two trim tab switches. (Refer to page 21 for trim tab operation). The boat also comes standard with a compass mounted on top of the console.



Switch Panel



Compass

## Command Link Gauge

Yamaha's CL5 gauge comes standard on your new Cobia. The Yamaha CL5's main screen is equipped to read out the vessel's speed, RPM, GPH, MPG, and a variety of vessel health items. The CL5 also has a multitude of features and information that can be accessed through the gauge's menu. For more information on the specifics of your Yamaha gauges, see your Yamaha owner's manual.



Yamaha CL5 Gauge

## Navigation Lights

Your Cobia 265CC is equipped with port and starboard navigation lights and an anchor light. Navigation and anchor lights should not be modified, and additional lights should not be added such that they diminish the visibility of navigation lights or could be confused with navigation lights. Both navigation and anchor lights come labeled with an expiration year in which the lights need to be replaced by. Reach out to your local dealer or the manufacturer to replace lights.



### Maverick Boat Group

3207 Industrial 29th St. • Fort Pierce, Florida 34946  
(772)-465-0631 • [cobiaboats.com](http://cobiaboats.com)

- Navigation Lights
  - Part number: 43020000
  - Expiration Year: 2043
- Anchor Light
  - Part number: 43029010 standard; 43029610 with Hardtop; 43029611 with Hardtop and Radar
  - Expiration Year: 2043

## Cobia Duffel Bag

Along with your boat, you received a Duffel Bag with your new Cobia. Inside the Duffel Bag are the following items:

- Livewell Standpipe
- 2 ignition Keys and Emergency Kill Cord /Engine Stop Lanyard
- Various Accessories Manuals

# Fuel-Water Separator & Drain

## Fuel-Water Separator

The Yamaha Fuel-Water Separators are installed in the port side of the bilge, accessible through the aft bilge hatch. The new, improved 10-micron filter provides superior filtration ahead of the engine's on-board filters and injectors.

Large filtering and water capture areas maximize filtration while maintaining adequate flow rate for larger engines. The fuel separator can be checked by removing it from the mounting bracket and dumping it into an approved waste collection device. If there appears to be an excessive amount of water, the filter component should be replaced. See your authorized Cobia Dealer for replacement parts.





**Maintenance Note:** Yamaha recommends replacing the 10-micron fuel filter on new boats after the first 10 hours or 1 month of operation and every 50 hours or every 6 months thereafter. In areas of high humidity where water in fuel supplies is a problem or extensive engine operation occurs, more frequent replacement may be necessary.

## Garboard Drain Plug

The garboard drain plug is the small metal plug located at the lowest point on the hull, at the bottom of the transom right above the keel. The drain has been designed so that it can be loosened by hand while the hull is out of the water for draining. This allows the plug to stay in contact with the surrounding frame, so you'll never misplace or lose it. You can completely remove the insert by pulling back and continue turning in a counterclockwise motion. It is manufactured with a rubber seal in place to ensure your bilge is watertight. Always make sure before putting the boat in the water that this plug is hand tightened firmly. Excess water in the bilge may be an indication of a problem with this plug or the automatic bilge pump.



*Drain Plug*

# Bilge

## Bilge Access

Accessing the bilge in your 265 is made easy. First, locate the controls on the electronic lift assist, labeled "Hatch", mounted on the starboard side of the tackle station directly across from the gunwale. Next, press and hold the top button on the controls. This will cause the rear access to lift revealing the bilge access. To lower the hatch simply press and hold the bottom button on the control panel until the aft section is fully closed. Remember that the electronic lift assist operates using the house battery system.

In the event that the boat does not have power to electronically lift the hatch, the electronic lift can be disengaged by lowering the bench seat and using the access opening shown below to remove the pin from the electronic ram. Keep in mind that at this point the hatch will no longer be supported in the up position and will require being held up to maintain access to the bilge. Once the work in the bilge is finished and power is restored to the hatch lift, it is important to attach the ram to the hatch with the pin once again to secure the door in the closed position.



*Electric Ram and Hatch Pin*



*Hatch Control*



*Bilge Access*



*Electric Ram Override Access*

## Bilge

The bilge of your Cobia should always be checked before and after a launch. While checking the bilge, note that a small amount of water in the bilge is normal. However, a large amount of water or any signs of fuel or oil requires immediate attention. **If such a situation exists, the boat should be taken to a certified marine technician immediately. Never pump fuel or oil overboard while your boat is in the water.**

Large quantities of water in the bilge may be an indication of a leak or that the bilge pump and/or automatic float switch is not functioning properly due to a jam, clog or electrical issue. The automatic float switch is wired to the hot side of the battery switch through the “BILGE” fuse at the battery switch panel. When functioning properly, the float switch activates the bilge pump to pump water overboard once water in the bilge reaches a level that submerges the switch.



*Aft Bilge Pump and Float Switch*

If the bilge pump does not come on when the float switch is submerged, attempt to manually turn it on through your switch panel. If the bilge pump comes on and evacuates the water, it is clear that the float switch is not functioning properly. If the bilge pump does not come on via the switch panel, check the breaker panel inside the console to see if a breaker has been tripped. If the breaker has been tripped, reset it and turn the switch on again, listening for the bilge pump to turn on.

If the bilge pump fails to turn on, turn the battery switch to the OFF position, then unhook the bilge pump from its cradle by pressing the locking tabs and lifting the pump straight up. The entire bilge pump and wiring should release from the cradle. After removing the pump, check the underside and impeller areas for miscellaneous items that might clog the pump. If any obstructions are present remove the debris and set the pump back into the cradle. Once set back in the cradle, press the pump down on the base until the lock button snaps it into place. Once this is completed you can try to turn the pump on again.

If the bilge pump still does not turn on, it likely needs to be replaced. It is not recommended to use your boat if the bilge pump and/or float switch are not functioning properly.

## Systems

### Ball Valves

Ball valves can be used to serve several purposes. They allow seawater to enter the boat, in the case of livewells, and they also act as a safeguard to stop water from entering. To tell which position a ball valve is in, open or closed, look at the valve and determine the direction of flow. When the ball valve handle is in the same position as the direction of flow, the valve is in the “OPEN” position. When the ball valve handle appears to cross the direction of flow, the valve is in the “CLOSED” position. The ball valves can be accessed in the bilge compartment behind the aft seating.

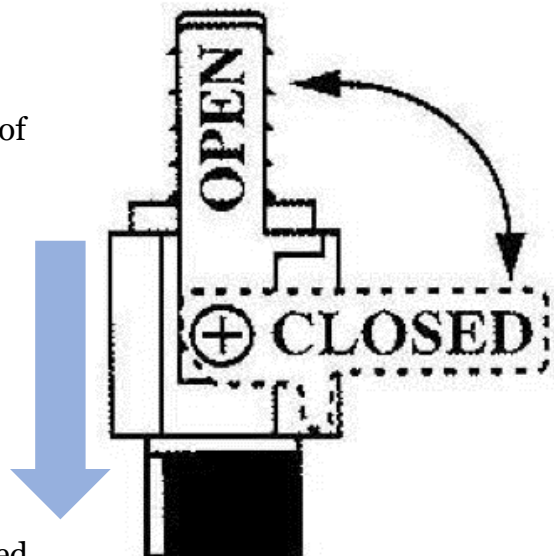

## 265 Deck Drain System

The deck drain system is equipped with 1 1/2" thru hull fittings through the aft port and starboard hull sides. These fittings have to be installed lower than the drains in the cockpit floor so that gravity will allow the cockpit to drain free of water. This puts these fittings very close to the water line of the hull. These drains are rigged with ball valves that can be opened and closed to control the flow of water. In the open position, these ball valves will allow water to flow freely from the cockpit, thus making the boat "self-bailing". When closed, no water will be allowed to travel to or from the cockpit.

## 265 Livewell Pump Assembly

The livewell pump assembly is composed of a scoop strainer mounted to the bottom of the hull, a thru hull fitting, ball valve assembly, and the pump. As you can see, the ball valve assembly is in the "OPEN" position. This is the correct position for the operation of the livewell.

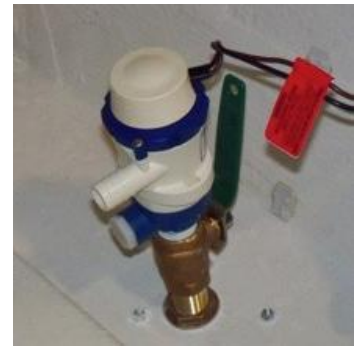

*Livewell Pump in the "Open" Position*

## Head Unit

Inside the console is the head unit. There are steps that lead into the head unit which houses a freshwater sink, lighted towel-rack bar, optional electric head, switch panel for flushing head, and on-off switch for the macerator. The main DC breaker panel (for switch panel accessories) is inside along with two port hole windows. There is also access to the macerator, y-valve, water intake and discharge for the toilet and holding tank. Lift the forward console seat cushion for access to a built in 62 qt cooler.



## Console/Head Access

Located at the top on the inside of the console/head access door is a locking gas shock that aides in opening the door and keeping the door open once the shock is fully extended. With the door fully opened, it can only be closed by releasing the pressure of the metal sleeve on the door side against the shock that is mounted to the console. To do this, open the door to its fullest open position, thereby allowing the door slide sleeve to be moved so that it will slide overtop of the gas shock as the door closes. Failure to release this locking mechanism while attempting to close the door will lead to the gas shock failing, or damage to the mounting brackets.



Gas Shock

## Optional Electric Head

The macerator is to be used only with direct discharge thru hull. The macerator will not be used for dockside pump out of the holding tank. To flush the head, make sure intake valve is in the open position, supplying your head with the water it will need to operate correctly. Then press the toilet switch and the waste is pushed into the holding tank. The intake and discharge valves are located in the fwd bilge access area under the sink. The macerator has nothing to do with the flushing of the toilet as it is only used for overboard discharge while outside the legal dumping limits. To discharge outside legal limits, open the thru hull discharge valve located behind the intake valve, turn the Y-Valve so the arrow towards the macerator is exposed, and flip macerator switch to the "ON" position. The Y-Valve and macerator pump are also located in the fwd. bilge access area.



Macerator Pump

Y-Valve

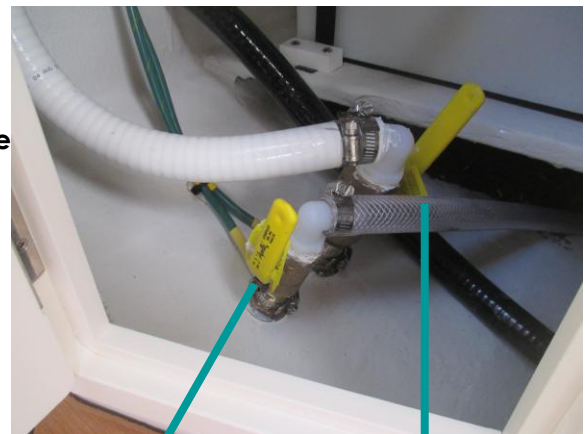

Intake Valve (open)

Discharge Valve (open)

The Jabsco Y-Valve is designed to provide flexibility of onboard waste management by diverting waste either to the dockside pump-out fitting or directly overboard where legal to do so. Check local and federal regulations to determine where direct overboard discharge of untreated waste is permitted.

Some near shore areas and inland areas are designated as "No- Discharge Zones" where the discharge of any onboard waste, even treated waste, is strictly prohibited. **Many of these areas require a waste retention system that can be positively secured in an onboard retention mode.**

The Jabsco Y-Valve accommodates this requirement by providing the ability to add a padlock that secures the selector handle in either direction to ensure waste is directed to an onboard holding tank. The Y-Valve may also be used to direct waste from a holding tank to a waste deck plate for removal by a dockside pump-out facility.



*Macerator Used for Pumping Direct Overboard Discharge*



*Y-Valve Used to Direct Waste Discharge*

# Ladder & Props

## Stainless Boarding Ladder

This Cobia model comes standard with a telescoping stainless-steel boarding ladder integrated into the port aft platform area. This provides a stepping area while the ladder is in the up position. Once the ladder is down and in the extended position, close the lid cover for safe and secure entry and exit via the ladder. The ladder is the designed method for unassisted reboarding should the situation arise. When washing off your boat at the end of the day make sure to extend the ladder and wash it off as well, making sure to dry it completely before stowing. Leaving saltwater in the telescoping tubes may lead to corrosion and affect the useful life of your ladder.



### DANGER:

No passenger should attempt to enter or exit the boat by the ladder or by any other means while the engine is on.

## Props

Prop selection on your Cobia is based on recommendations from Yamaha Marine in order to give your boat maximum overall performance. The needs of your prop will determine the prop design and size that best fits your performance requirements.

Always inspect the engine and prop prior to launching your boat with the engine off. Key prop issues include tangled fishing line or other types of debris, cracked blades or fluid leaking out of the seal. Look for fishing line tangled around the prop or lower unit seal. **Consult your Yamaha Owner's Manual to address these issues.**



Engine Prop



Maverick Boat Group

3207 Industrial 29th St. • Fort Pierce, Florida 34946  
(772)-465-0631 • [cobiaboats.com](http://cobiaboats.com)

# Fuel System

## Fuel System

The Cobia 265 CC comes equipped with a 161-gallon fuel cell stationed below the leaning post between the stringer system. Every fuel tank is pressure tested at the factory before and after installation. Should you experience any fuel related problems or suspect problems with the fuel system, immediately take your boat to a Cobia Dealer.



*Fuel Fill Receptacle*

The fuel sending unit and fuel pick up on the tank can be accessed at the pie hole on the cockpit floor behind the leaning post. The fuel vent and the fuel fill at the tank can be accessed at the pie hole forward of the leaning post. The primer bulbs are located next to the fuel-water separators in the bilge access hatch (see page 9).

### **DANGER:**



Do not smoke while filling the tank. Be sure to turn off the engines and all electrical equipment when fueling the boat to prevent accidental discharges of static electricity. Use only the recommended gasoline (see Yamaha Owner's Manual). Do not use fuels with alcohol or alcohol related derivatives that can cause marine fuel system hoses to deteriorate.

# Self-Bailing Cockpit & Livewell

## Self-Bailing Cockpit

The cockpit is designed to be self-bailing, meaning that all the water that comes into the cockpit will be directly drained overboard. This keeps the boat from acquiring standing water and allows the boat to drain at all times, including while the boat is docked.

Water drains out of the cockpit through four aft cockpit drains located at the far aft cockpit floor on both the port and starboard sides. Each side drains overboard through the



*Cockpit Drain*



**Maverick Boat Group**

3207 Industrial 29th St. • Fort Pierce, Florida 34946  
(772)-465-0631 • [cobiaboats.com](http://cobiaboats.com)

side of the hull independently. None of this water is drained into the bilge. The ball valves are located behind the aft seating. Refer to page 12 for operation of the ball valve associated with this system.

The bilge is designed to drain any water entering the inside of the hull. All hoses are sealed and double clamped during construction. Continuous or periodic running of the automatic bilge pump may be an indication of a hose leak or break in a seal and should be investigated by a Cobia Dealer immediately. Refer to page 10 for further information regarding bilge pump operation and maintenance.

## Livewell System

The livewell system is designed to keep your baitfish alive and strong for as long as possible. This 30-gallon livewell provides a cool, clean, and oxygenated environment that allows you to keep your baitfish alive for long periods of time. To efficiently operate your livewell, the following steps should be taken:



1. **Open livewell hatch.**
2. **Install stand-up pipe snugly.**
3. **Ensure livewell pump ball valve is in open position.**
4. **Turn on livewell switch.**

The livewell operates by pumping fresh seawater from the pump through an aerator head into the livewell. Drainage is achieved through the grate on the top of the standpipe, which, when unobstructed, will limit the water level to the standpipe's highest point. A shorter standpipe can be used to keep less water in the well. This constant drainage keeps up water flow and allows for the removal of ammonia from the livewell, therefore extending the life of your baitfish. To drain the livewell, switch off the pump, close pump ball valve, and remove standpipe.

# Rod Storage & Fish Lockers

## Rod Storage

The 265 Center Console model comes standard with under gunwale rod racks on both the port and starboard sides. These give you space to safely store an additional 6 rods for your fishing needs.



*Starboard Gunwale Storage Rack*

## Port and Starboard Fish Lockers

The 265 CC has two 46-gallon fish lockers built into the aft cockpit floor on the port and starboard sides. These are insulated, and each connected to a macerator with the contents being dumped overboard. The macerators are located in the bilge on the outboard sides of the stringers. They can be accessed through the bilge access hatch under the aft folding seat.



*Fish Locker*

## Macerator Switches

The switches for each fish box macerator are located on the switch panel left of the steering helm and are labeled accordingly. The pumps can only be operated independently of each other.

# Anchor Locker

## Anchor Locker/Rode Storage

The anchor locker is located at the bow of the boat and is accessible through the anchor locker door or hatch (photo below). There is an eye mounted to the bow eye to secure your anchor rode or chain to. After setting your anchor, the excess rode can remain stored in the locker. The notch supplied in the door allows you to securely close the locker by aligning your rode through the notch. Optional windlass shown on page 29.



Anchor Locker

# Table Lift

## Table Lift

There is an optional electric table available on the Cobia 265CC. The table can be lowered all the way down to sit flush with the deck allowing full access to the bow area (1). It can be raised halfway to sit flush with the rest of the bow seating for an elevated viewing platform or simply more area to lounge (2). Lastly, at the fully extended position, it functions as a picnic style table with seating all around (3). The table lift switch is located just behind the starboard side backrest in the bow seating area.



2



3

# Trim Tabs

## Trim Tabs

Bennett trim tabs are standard on your new Cobia. Integrated electric trim tabs can enhance the performance of your boat. The tabs are electric and therefore do not require a trim tab pump. By not having a pump there is no possibility of fluid leaks from a pump.

Trim tabs allow for maximum boat performance and are great for balancing weight in the boat. They also allow the boat operator to lift or lower the hull to accommodate for different running situations.

For the operation of trim tabs note that the port trim tab switch will affect the port side of the boat, and the starboard switch will affect the starboard side. To lower a particular side, press the top of the corresponding switch down. Pressing the top of both switches down will lower the bow evenly. To raise the bow, press the bottom of the corresponding switch.

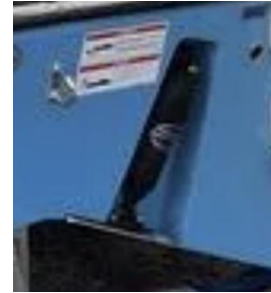

Trim Tab

# Water System

## Raw Water Washdown

Saltwater washdown is standard on the 265 CC model. The pump is located in the port bilge and is accessible through the flip up seat opening. To operate, hook a hose to the saltwater receptacle located by the transom gate above the port deck drain. Flip the switch labeled “Raw water Washdown”. The pump will pressurize the system with salt water. Once the system is pressurized, the pump will shut itself off with an internal pressure switch and will switch itself back on as you demand water. There is also a washdown fitting installed in the anchor hatch if equipped with windlass option (see pg. 29) to wash off the anchor rode. Be careful to only spray gel-coated fiberglass surfaces with saltwater and avoid all other areas. Always rinse your boat with freshwater as soon as you return to the dock or home if the boat is being trailered.



Washdown Fitting



Saltwater Pump & Intake Valve

## Fresh Water System

The freshwater tank on your 265 CC can be filled at the cap labeled “WATER” on the stern gunwale. To pressurize the system, flip the switch labeled “Fresh Wash Down” on the switch panel at the helm. You can leave this switch in the ON position while the boat is in use. The pump has an internal pressure switch that allows the pump to turn on and off as needed. This model has a 25-gallon freshwater tank.

In the colder months of the year, it’s advisable to drain the freshwater system and winterize by adding a non-toxic antifreeze to the system. Run the antifreeze throughout the system by opening shower nozzle until antifreeze is delivered through the shower head.



Water Fill



Washdown Fitting

# Battery Switch and Main Distribution Panel

The battery switches and main distribution panel are located on the starboard side of the leaning post. The battery switches are labeled to correspond with each battery and the component it powers. Each engine has its own battery and there is a house battery that powers the boat's other electrical systems. In the event that there is a second house battery on board, this battery will be tied to the house battery switch. When the boat is not being used for a prolonged period, it is recommended to leave all battery switches in the "off" position to ensure that the batteries are not drained due to minor current flows.

The forward and aft bilge pumps located at the top left of the panel, are on 24-hour circuits and will receive power at all times even with the house battery switch in the off position. This ensures that the bilge pumps and float switches will remain operational at all times unless the house battery loses all power. There is an additional 24-hour circuit with a 15-amp breaker labeled "ACC" left open for adding an accessory appropriate to 24-hour operation. To reset any of these breakers simply push in the button associated with the involved component.

On the bottom right of the panel is the windlass breaker. This is a gate style breaker. When the circuit is open or the breaker is "popped", a yellow tab will show in the recess just below the bar with the red button. Simply push the free end of the yellow tab back up inside the bar until it catches. The circuit is now closed and the windlass should be receiving power from the house battery. To open the circuit, simply press the red button.

In the top middle of the panel above the windlass breaker are the breakers for the forward table, power steering, electronics, helm panel, stereo amp (if applicable) and aft hatch. All these components run off the house battery (s). If popped these breakers will show red in the window below the "OFF" label on the left side of the switch. To reset push in the right side of the switch, "ON", so that it is flush with the panel.

It is important that all breakers match the amperage requirements of their associated components. The back of the breakers are labeled with their amperages and can be viewed by looking at the back of the panel as accessed through the battery access door on the front of the leaning post.



*Battery Switch (Shown in the Off Position)*

## Battery Access

The cranking batteries can be accessed by opening the door below the helm seat. The house battery or batteries are accessible through the access door in the head. Your boat will have a house battery (or two) that operates the general electrical features of the boat and a battery for each engine. Each battery should be able to be identified by the labels on the wires that lead to it. When replacing batteries, it is critical the wires be secured to the proper terminals precisely as they were on the previous battery(s).



*Cranking Battery Access*



*House Battery Access*

## 12-Volt Accessory Plug

The Cobia 265 Open comes with 4 12-volt accessory plugs standard on the boat. The plugs are located in the forward cubbies by the forward seating, the port side of the glovebox, and under the aft end of the starboard gunnel. Cell phones, media devices, spotlights or any kind of electronic accessory can be charged while remaining in a dry and secure area. If the plug is not providing power, check the appropriate breaker on the main breaker panel located inside the console.



*Glove Box*

# Seating

## Leaning Post

The leaning post for the 265 CC is home to the double bolstered helm seats that independently lock into the seated position or flip up to provide lumbar cushioning if the driver or passenger prefer to remain standing. The armrests can also be raised or lowered based on the preference of the user. There are various leaning post options that include additional tackle storage, an additional 50qt cooler, or a Seakeeper.



**Maverick Boat Group**

3207 Industrial 29th St. • Fort Pierce, Florida 34946  
(772)-465-0631 • [cobiaboats.com](http://cobiaboats.com)



*Pictured is Premium Helm Seat Option*

## 265 Aft Seating

To deploy the standard aft seat, grab the seat and pull down. Once the seat begins to swing open push on the topside of the cushion straight down until the seat is fully horizontal and locks in place. To stow the seat, repeat the procedure in reverse by lifting from the base. Once free of the hinge catches, the seat will begin to close. At this point, push the seat up until it's firmly against the back wall. When the seat is fully closed the cushion should be flush against the back wall with the seat securely positioned in the intended recess.

The backrest is mounted on a hinged lid and is used by gripping the bottom side of the lid and lifting. To stow the backrest, simply reverse the motion until the lid is closed. Refer to page 38 for cushion care instructions.



*Aft Seat and backrest in deployed position*

# Standard Features

## Cockpit Bolsters

Cockpit bolsters are standard with the 265 Open. The bolsters that line the outside of the rear cockpit are hard mounted to the gunwale boards and are designed to stay on the boat. These provide a comfortable position while fighting fish or simply leaning against the rail. Refer to page 38 for cushion care instructions.



## Pull Up Cleats

The cleats are stainless steel pull up style and can remain hidden when not in use. This is especially helpful while fishing as it leaves nothing to interfere with your line. To raise the cleats simply grip the indents and lift until locked. To recess these items simply push them back into the deck. As with all stainless moving parts on your Cobia, it is recommended that you routinely apply a stainless safe corrosion inhibitor and lubricant to keep these items working properly.



## Optional Bow Cushion Set

The 265 CC comes with the option of a 11-piece bow cushion set. These cushion bottoms are removable and are held in place by several sets of stainless-steel snaps. To remove the cushions, simply pull the snap strap away from the embedded snap and remove and store the cushion. When left outside or exposed to the elements for a prolonged period of time, it is recommended to take off the seat cushions and store them in a dry place like the head area. Refer to page 38 for cushion care instructions.



## Hardtop

The Cobia 265CC has an optional fiberglass hardtop that comes with an integrated glass enclosure to help keep out the elements. The hardtop is equipped with forward and aft spreader lights and overhead lights that can be changed from white light to blue. The hardtop is also equipped with aft rod storage on the frame as well as optional kingfish rod holders on the aft end. The hardtop can also be equipped with 4 JL Audio speakers in white or black to bolster the audio system.



## Hard Top Storage



### Maverick Boat Group

3207 Industrial 29th St. • Fort Pierce, Florida 34946  
(772)-465-0631 • [cobiaboats.com](http://cobiaboats.com)

The storage hatches are conveniently located directly above the helm and are spacious enough to hold any electronics or related accessories, personal flotation devices, or items you would like to keep secure and dry while under way or during storage. They feature locking latches as well as hatch springs that hold the door in the open position when fully extended providing easy access.



*Rear Hardtop Storage*



*Forward Electronics Storage*

## Optional JL Stereo System

If you chose the stereo option, your 265 CC came with a JL Audio Media Master 105 with six matching JL audio speakers (ten matching speakers if hard-top option is chosen) and two matching subwoofers. Please refer to the JL Audio Owner's Manual in your ditty bag for operation. Even if your boat didn't come with the stereo, your boat is pre-wired for four speakers in the cockpit and for four speakers in the hardtop. (Refer to pictures below for general locations of speakers and pre-pulled wiring.) The two amplifiers used to power the system are located in the forward floor storage area.



*JL Stereo System*

## Optional Windlass Deluxe



**Maverick Boat Group**

3207 Industrial 29th St. • Fort Pierce, Florida 34946  
(772)-465-0631 • [cobiaboats.com](http://cobiaboats.com)

The windlass is used to lower and raise your anchor assembly. The switch is mounted at the helm station to the left of the steering wheel. The solenoid switch is mounted in the leaning post and the battery cables are run up the starboard side. The windlass is mounted inside the anchor locker at the bow of the boat. To access this area, lift the anchor hatch at the bow. A bow plate and anchor roller have been added to accept the anchor and keep it far enough from the bow of your 265 CC to prevent damage to the bow. The windlass is mounted just aft of the bow roller plate.



The Windlass breaker is located on the battery switch panel in the port compartment on the side of the leaning post. The windlass solenoid is mounted just above and to the left of the breaker panel. For more information on the breaker, see page 23.

**Please review the manufacturer's operating instructions on the following pages before using your windlass. Additional information can be found in the Lewmar owner's manual.**

## **WARNING: READ ALL INSTRUCTIONS BEFORE OPERATING WINDLASS**



DO NOT USE THE WINDLASS TO DRAG THE BOAT TO YOUR ANCHOR. THE PROPER METHOD IS TO USE YOUR BOAT'S OWN POWER TO POSITION YOURSELF RIGHT ABOVE THE ANCHOR AND THEN USE THE WINDLASS TO HAUL THE ANCHOR. STAY CLEAR OF THE CHAIN, ROPES, AND GYPSY. MAKE SURE THE ELECTRICAL MOTOR IS OFF WHEN WINDLASS IS USED MANUALLY (EVEN WHEN USING THE HANDLE TO DISENGAGE THE CLUTCH). IN FACT, PEOPLE WITH A REMOTE CONTROL MIGHT ACCIDENTALLY OPERATE THEIR CONTROL. FASTEN THE CHAIN OR ROPE WITH THE SAFETY LANYARD BEFORE MOVING TO NAVIGATION. DO NOT OPERATE THE WINDLASS BY USING THE ELECTRICAL POWER WHEN THE LEVER IS INSERTED INTO THE DRUM OR IN THE COVER OF THE GYPSY.

## 6. Operation

### 6.1 Operating tips

Vessels at anchor will snub on the rode and this can cause slippage or apply excessive loads to the windlass.

1. When anchoring, power rode out allowing the vessel to take up stern away preventing the rode tangling with anchor. Use this method for mooring stern first to a jetty.
  2. To aid recovery, under power, move vessel towards anchor but not over and beyond, as this can cause damage to topside.
- As anchor approaches the vessel, use careful adjustments of controls to avoid damaging vessel.
  - Scope: As a guide it is recommended that the depth of chain to rode is 7 to 1 at anchor.

⊘ The rode should be secured directly to a bollard, sampson post or cleat and a chain secured by a chain stopper.

⊘ When retrieving anchor do not overload or stall in windlass.

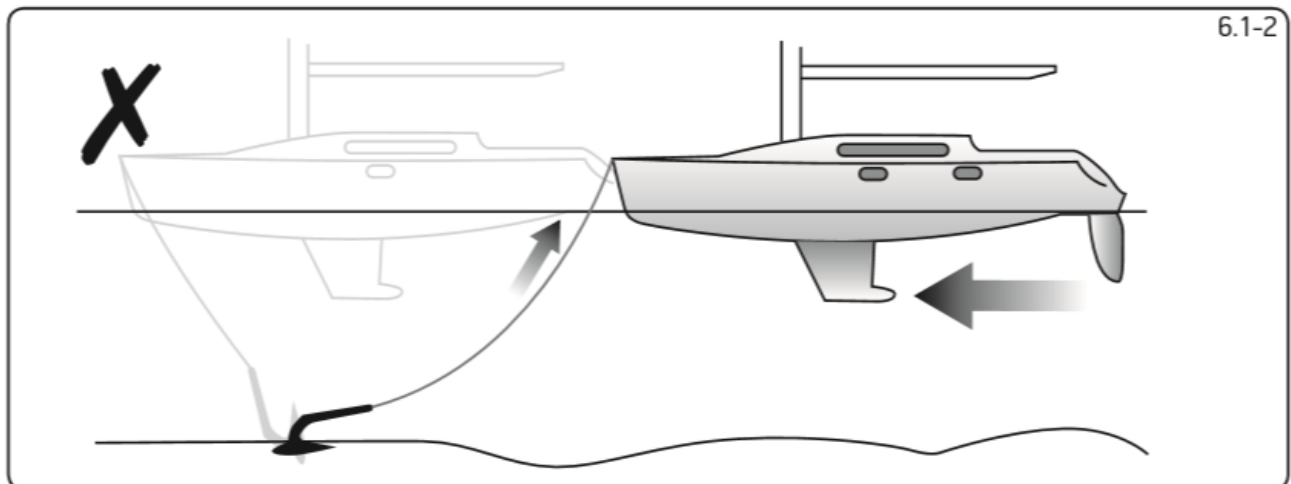
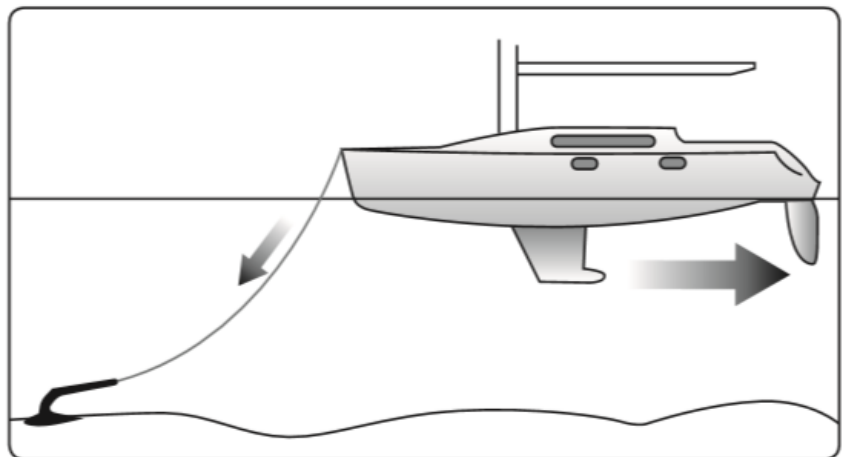
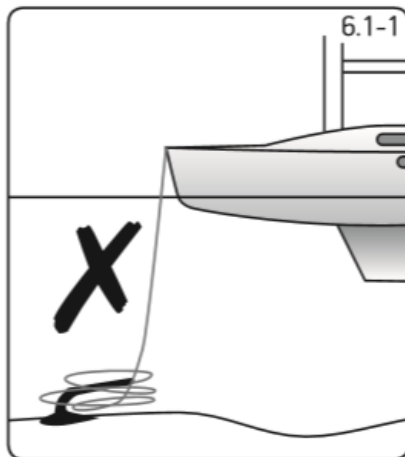

## 6.2 Use of clutch

To tighten the clutch - using the clutch lever supplied, rotate the gypsy drive cap (31) clockwise, this will grip the gypsy, effectively locking it to the windlass geartrain.

To slacken the clutch - turn the gypsy drive cap anti-clockwise, this will free the gypsy allowing it to turn independently of the windlass geartrain.

⚠ Always remove the handle after use.

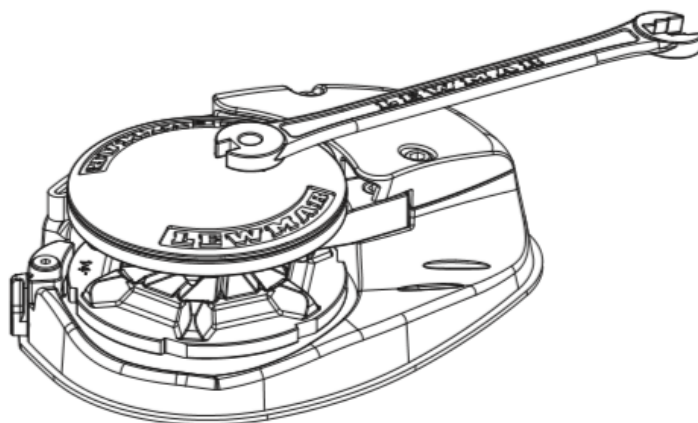

## 6.3 Letting go under gravity

⚠ Always check the fallsafe pawl (32) is disengaged from the gypsy and held clear of it by the fallsafe lever (34).

Insert the clutch lever into the gypsy drive cap (31) and turn it clockwise to ensure that the clutch is tight. Release any independent anchor locks. If it is safe to do so, pull back on the clutch lever until the anchor and rode begin to pay out. Control the rate of decent of the anchor by pushing the clutch lever forwards. When sufficient rode has been paid out, fully tighten the gypsy drive cap once again.

⊘ For maximum safety and to prevent damage, the fallsafe pawl **MUST NOT** be left to take the entire force from the anchor rode while at anchor. The rode should be made fast directly to a bollard, sampson post or cleat.

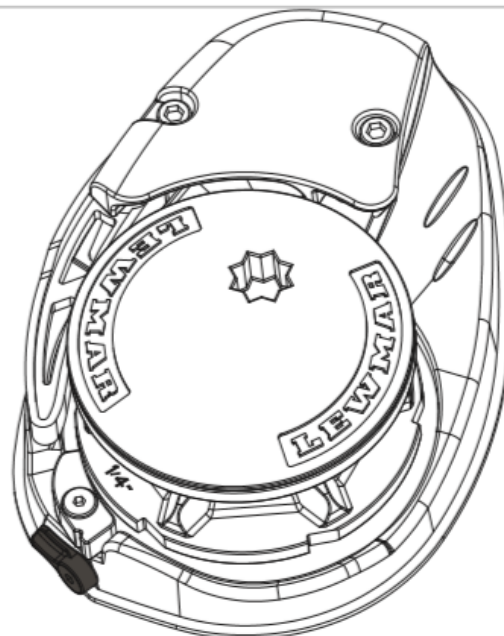

## 6.4 Letting go under power

Release any independent anchor locks.

If it is safe to do so, let go under power by operating a 'Down' control. Release the control when sufficient rode has been paid out.

## 6.5 Lying to anchor safely

Vessels at anchor will snub on the rode and this can cause slippage or apply excessive loads to the windlass.

## 6.6 Hauling in

---

Untie the bridle or replace the rode in the gypsy.

If it is safe to do so, operate an 'Up' control.

The fallsafe pawl (32) does not need to be disengaged during retrieval as it will act as a ratchet. When the anchor has been retrieved and is stowed in the bow roller, the fallsafe pawl should be left engaged in the gypsy to prevent accidental deployment of the anchor whilst underway.

REMEMBER - The fallsafe pawl DOES need to be disengaged from the gypsy before the anchor can be let go again.

Having retrieved the anchor, ensure it is independently secured to prevent its accidental release.

## 6.7 Manual recovery

---

Insert clutch lever supplied into gypsy drive cap (31) and turn clockwise to haul in the anchor.

## 6.8 Operating tips

---

When anchoring, it is best to power the rode out, allowing the vessel to take up stern way before full scope is let out. This helps prevent the rode from becoming tangled on top of your anchor on the seabed.

To aid anchor recovery, we recommend that the vessel's engine be used to assist by moving the vessel towards the anchor. We do not recommend that the vessel be motored over and beyond the anchor, as this can cause the rode to damage your topsides.

As the anchor approaches the stemhead, the last few feet of rode should be inched in by judicious use of controls to avoid damage to the vessel.

Having retrieved the anchor, ensure the fallsafe pawl is engaged in the gypsy to lock it and prevent accidental deployment of the anchor whilst underway.

When mooring stern to, at a suitable distance from the jetty, deploy the anchor to prevent the bow from swinging. Gently pay out the rode under the influence of the stern way of the vessel as it approaches the jetty. Make fast your vessel with warps from the stern.

## 6.9 Joining rope to chain

---

When splicing rope to chain, select a length of chain that will avoid having the splice positioned in the gypsy when the anchor comes over the stemhead. Furthermore, ensure that the splice is no tighter than the rope.

A hard splice is not desired.

- With whipping twine or similar, seize your rope 200 mm (8") from the rope's end and unlay the strands.
- Pass one strand through the chain link from one side and the other two strands from the opposite side. Remove seizing and complete a back splice in the normal manner for four full tucks.
- With a hot knife pare down the three strands by one half of their diameter and continue with two further tucks.
- With a hot knife, carefully melt the ends back into the line. Because of wide variations in rope type and construction some experimentation may be required.
- Whip the line with permanent whipping at the beginning of the taper.
- The method of joining illustrated is designed to minimize chafe between the rope and chain but as a matter of prudent seamanship the splice should be checked regularly and remade if there is any evidence of wear.

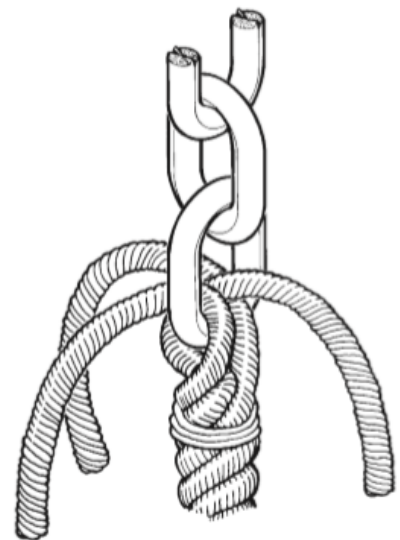

# Optional Features

## Optional Battery Charger

A 4-bank and 3-bank battery charger are options for the 265 CC. The 4-bank will allow charge to the cranking and house batteries, while the 3-bank battery charger will charge the optional trolling motor batteries. The 4-bank charger is mounted in the leaning post and can be accessed via the battery storage door underneath the helm seat. The 3-bank charger is mounted under the sink area in the head and is accessible through the removable potato bin. The filler piece also completely removes for greater access. This onboard charging system allows you to charge the boat's batteries directly from a standard 110-volt electrical outlet and extension cord. The 4-bank plug-in receptacle is located on the starboard side of the leaning post on the starboard side. Simply remove the cap to reveal the male plug inside. The 3-bank plug-in receptacle is located at the bottom of the starboard aft side of the console.



Plug-In Receptacle



Battery Charger

# Location and Reordering of Warning Labels

**WARNING**

Visibility from the seated position at this helm station is limited. Operation from a standing position may be necessary. Avoid serious injury or death from collisions. Maintain a lookout as required by USCG Navigation Rules. Read owner's manual.

IF LABEL IS DAMAGED, REMOVED, OR LOST, REPLACE WITH NEW LABEL, PART NO. 59118503, AVAILABLE FROM DEALER OR MANUFACTURER. INSTALL NEAR KEY SWITCH

**WARNING**

Carbon monoxide (CO) can cause brain damage or death. Engine and generator exhaust contains odorless and colorless carbon monoxide gas. Signs of carbon monoxide poisoning include nausea, headache, dizziness, drowsiness, and lack of consciousness. Get fresh air if anyone shows signs of carbon monoxide poisoning. See Owner's Manual for information regarding carbon monoxide poisoning.

IF LABEL IS DAMAGED, REMOVED, OR LOST, REPLACE WITH NEW LABEL, PART NO. 59118503, AVAILABLE FROM DEALER OR MANUFACTURER. INSTALL NEAR KEY SWITCH

**WARNING**

SUDDEN TURNS AT HIGH SPEEDS MAY CAUSE LOSS OF BOAT CONTROL WHICH COULD RESULT IN SERIOUS INJURY OR DEATH. REDUCE SPEED BEFORE ATTEMPTING A SUDDEN SHARP TURN. WOT-2020-3

IF LABEL IS DAMAGED, REMOVED, OR LOST, REPLACE WITH NEW LABEL, PART NO. 59118506, AVAILABLE FROM DEALER OR MANUFACTURER. INSTALL NEAR HELM

**WARNING**

Rotating propeller may cause serious injury or death. Shut off engine when near persons in the water. NADA NW 207-19

IF LABEL IS DAMAGED, REMOVED, OR LOST, REPLACE WITH NEW LABEL, PART NO. 59118502, AVAILABLE FROM DEALER OR MANUFACTURER. INSTALL NEAR KEY SWITCH

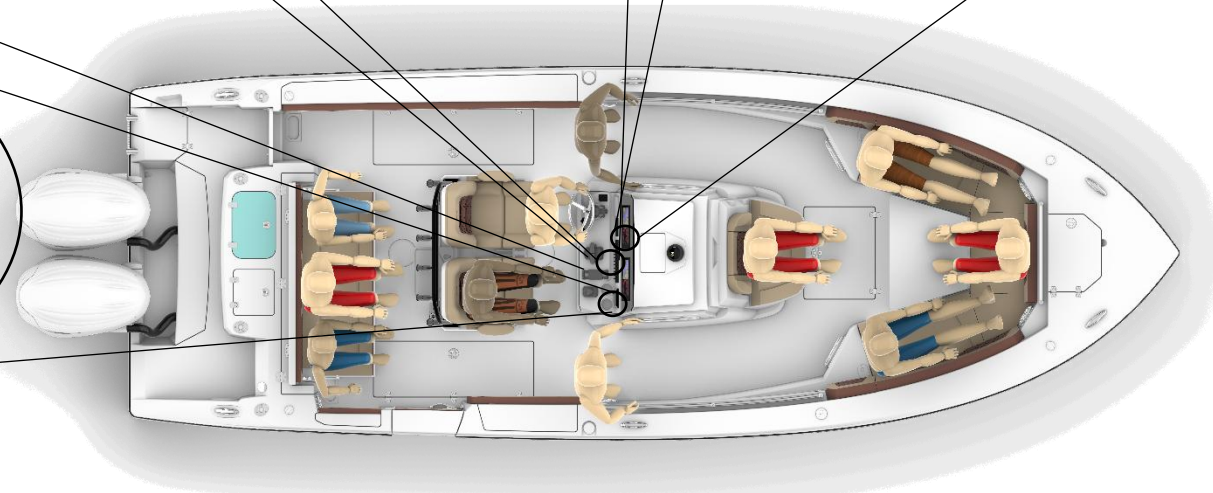

# Location and Reordering of Warning Labels

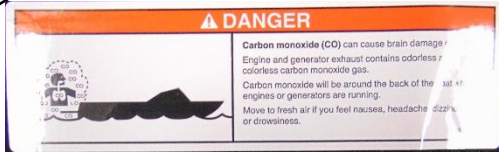

IF LABEL IS DAMAGED, REMOVED, OR LOST,  
REPLACE WITH NEW LABEL, PART NO. 59118502,  
AVAILABLE FROM DEALER OR MANUFACTURER.  
INSTALL ON TRANSOM

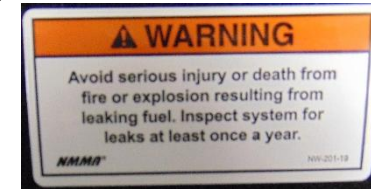

IF LABEL IS DAMAGED, REMOVED, OR LOST,  
REPLACE WITH NEW LABEL, PART NO. 59110900,  
AVAILABLE FROM DEALER OR MANUFACTURER.  
INSTALL NEAR FUEL FILL

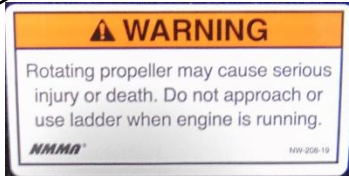

IF LABEL IS DAMAGED, REMOVED, OR LOST,  
REPLACE WITH NEW LABEL, PART NO. 59118502,  
AVAILABLE FROM DEALER OR MANUFACTURER.  
INSTALL ON TRANSOM

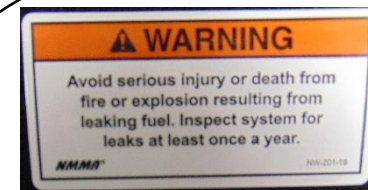

IF LABEL IS DAMAGED, REMOVED, OR LOST,  
REPLACE WITH NEW LABEL, PART NO. 59110900,  
AVAILABLE FROM DEALER OR MANUFACTURER.  
INSTALL NEAR FUEL FILL

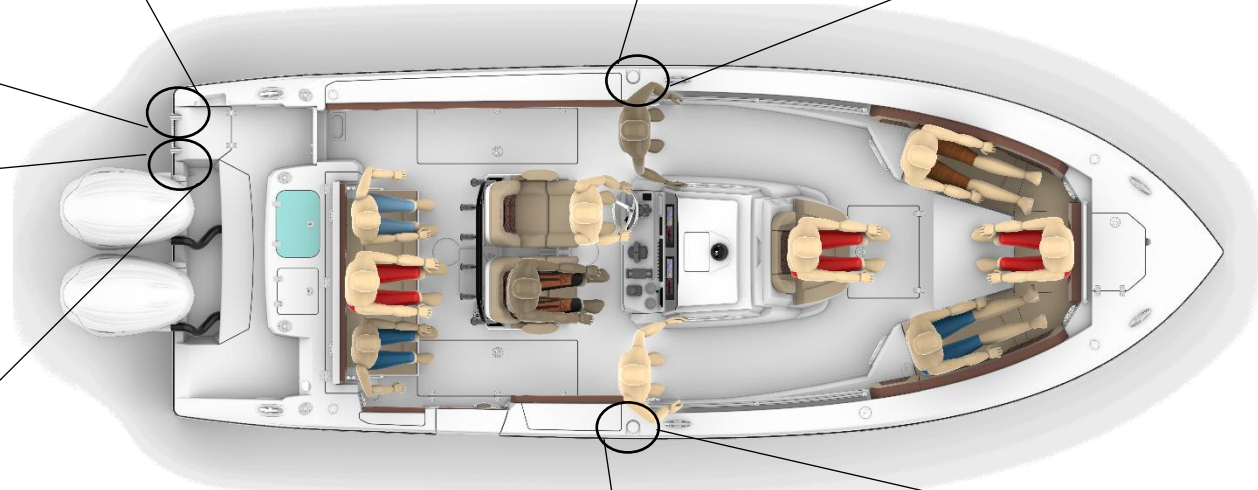

# Cobia 265 CC Hull Wire Harness

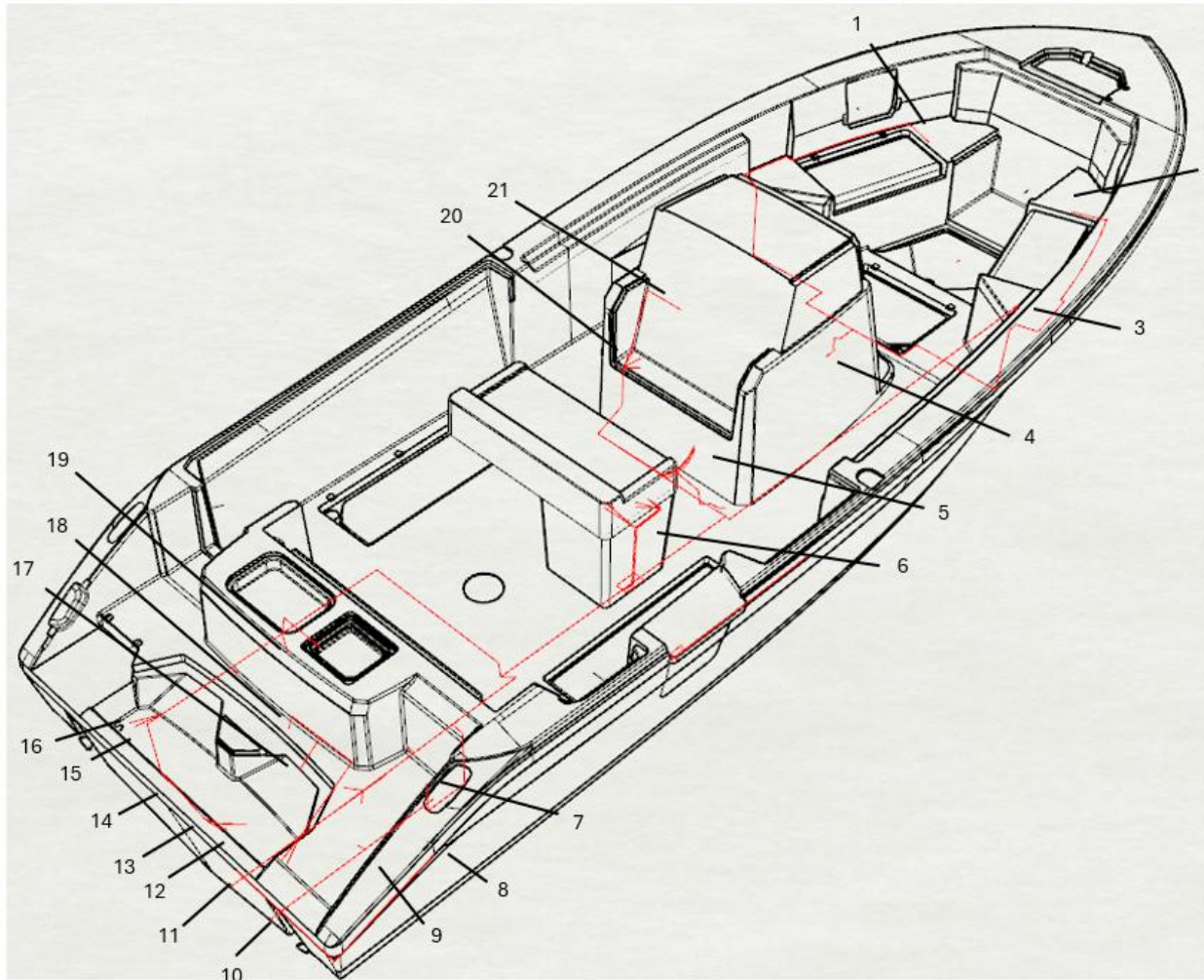

- |   |                              |
|---|------------------------------|
| 1. Pt Fwd Storage Cpt Lt                | 12. Aft Float Switch         |
| 2. Stbd Fwd Storage Cpt Lt              | 13. Aft Bilge Pump           |
| 3. Head Macerator                       | 14. Raw Water Pump           |
| 4. Head Cpt Lt                          | 15. Stbd Underwater Lt       |
| 5. Head Intake Pump                     | 16. Stbd Trim Tab            |
| 6. Battery and Breaker Panel Connection | 17. Livewell Pump            |
| 7. Windshield Washer Canister           | 18. Bilge Access Ram         |
| 8. Fishbox Macerator                    | 19. Livewell Lt              |
| 9. Fresh Water Pump                     | 20. Breaker Panel Connection |
| 10. Stbd Trim Tab                       | 21. Windlass Switch          |
| 11. Stbd Underwater Lt                  |                              |



## Maverick Boat Group

3207 Industrial 29th St. • Fort Pierce, Florida 34946  
(772)-465-0631 • [cobiaboats.com](http://cobiaboats.com)

# Cobia 265 CC Fwd Deck Wire Harness

1. Port Under Gunnel Lt
2. Fuel Fill Bonding Wire
3. Port Midship Speaker
4. Port Fwd Compartment Lt
5. Port Subwoofer
6. Port Seating USB
7. Port Fwd Speaker
8. Stbd Fwd Speaker
9. Fwd Compartment Lt
10. Stbd Seating USB
11. Stbd Subwoofer
12. Stbd Fwd Compartment Lt
13. Stbd Midship Speaker
14. Fuel Fill Bonding Wire
15. Stbd Undergunnel Lt

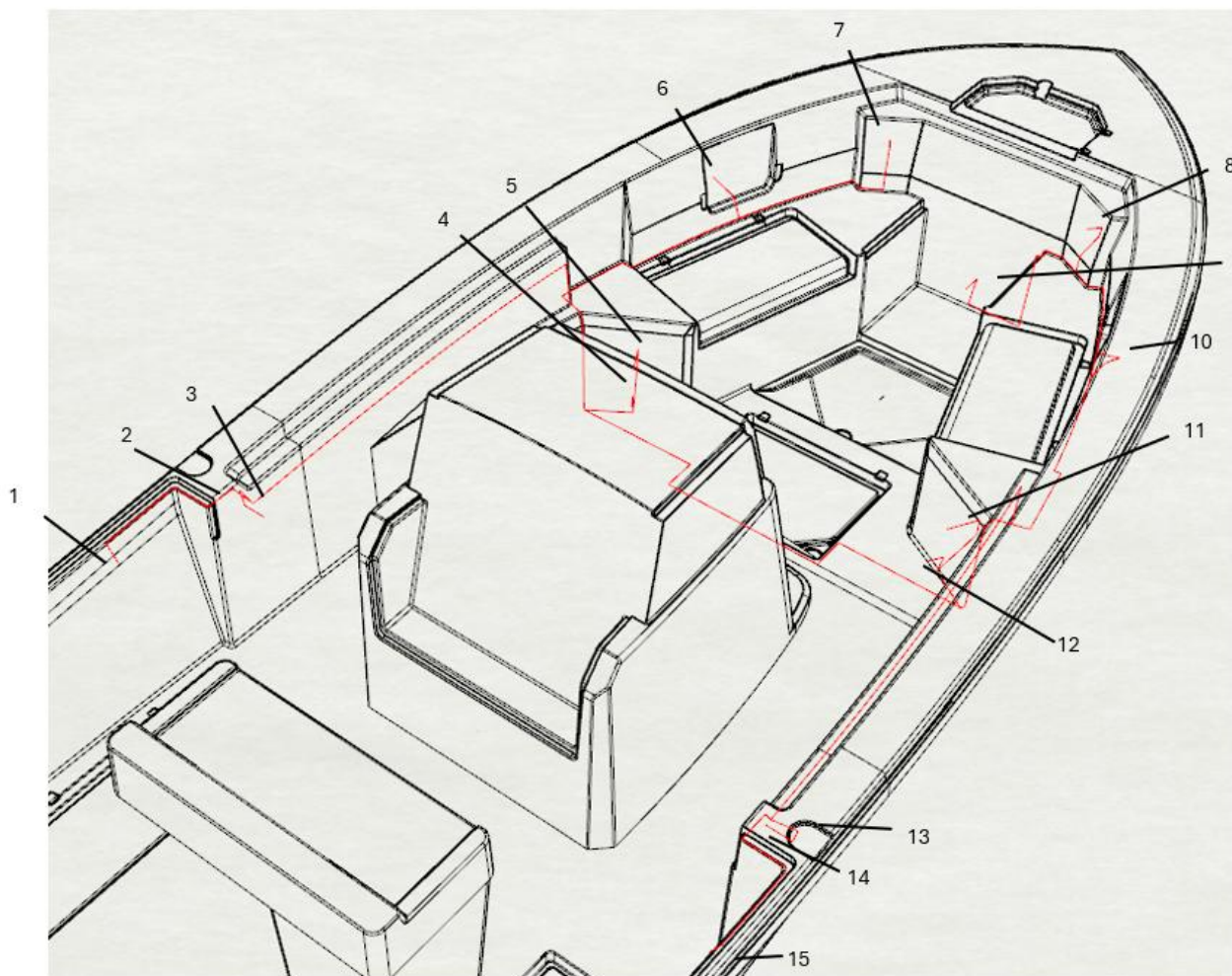

# Cobia 265 CC Aft Deck Wire Harness

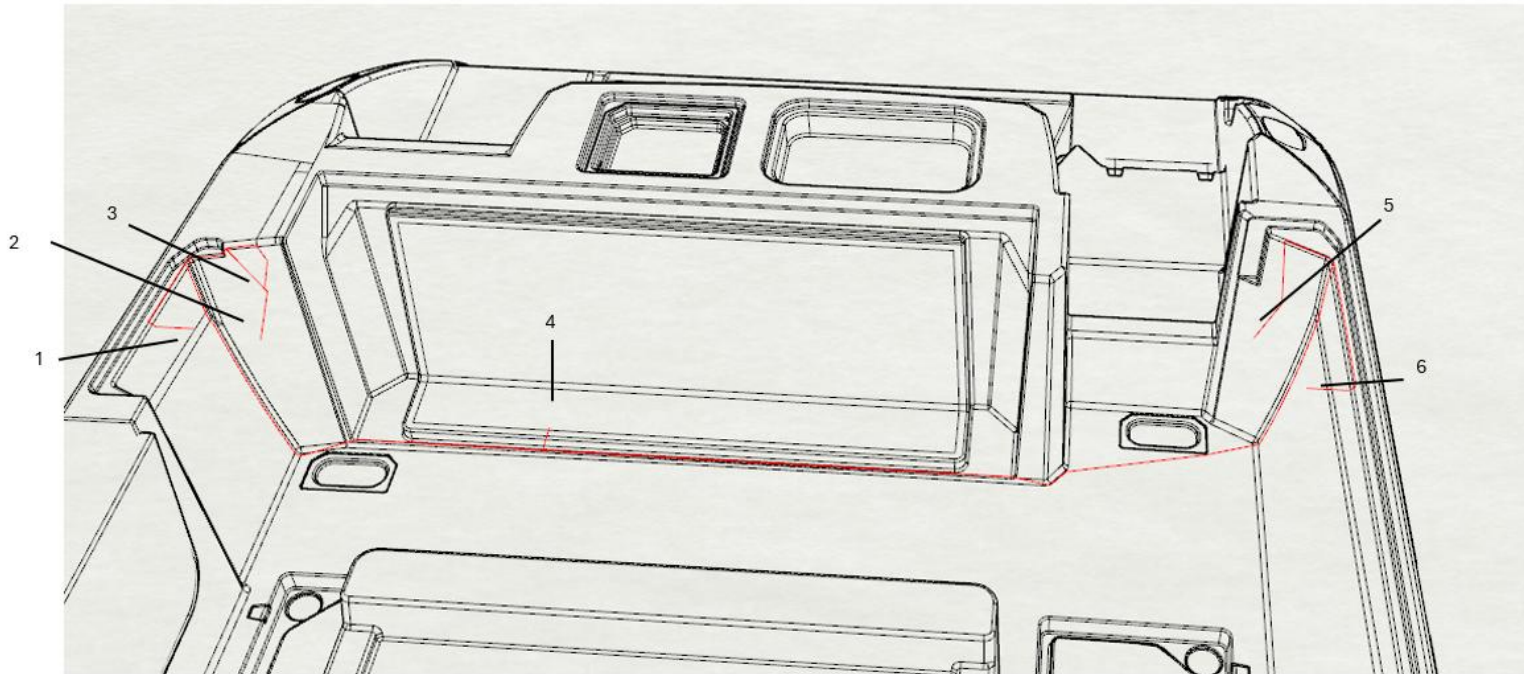

1. Starboard Aft Undergunnel Light

2. Starboard Aft Speaker

3. Starboard Aft USB

4. Hull and Deck Connection

5. Port Aft Speaker

6. Port Aft Undergunnel Light



**Maverick Boat Group**

3207 Industrial 29th St. • Fort Pierce, Florida 34946

(772)-465-0631 • [cobiaboats.com](http://cobiaboats.com)



# Cobia 265 CC Bunk Placement

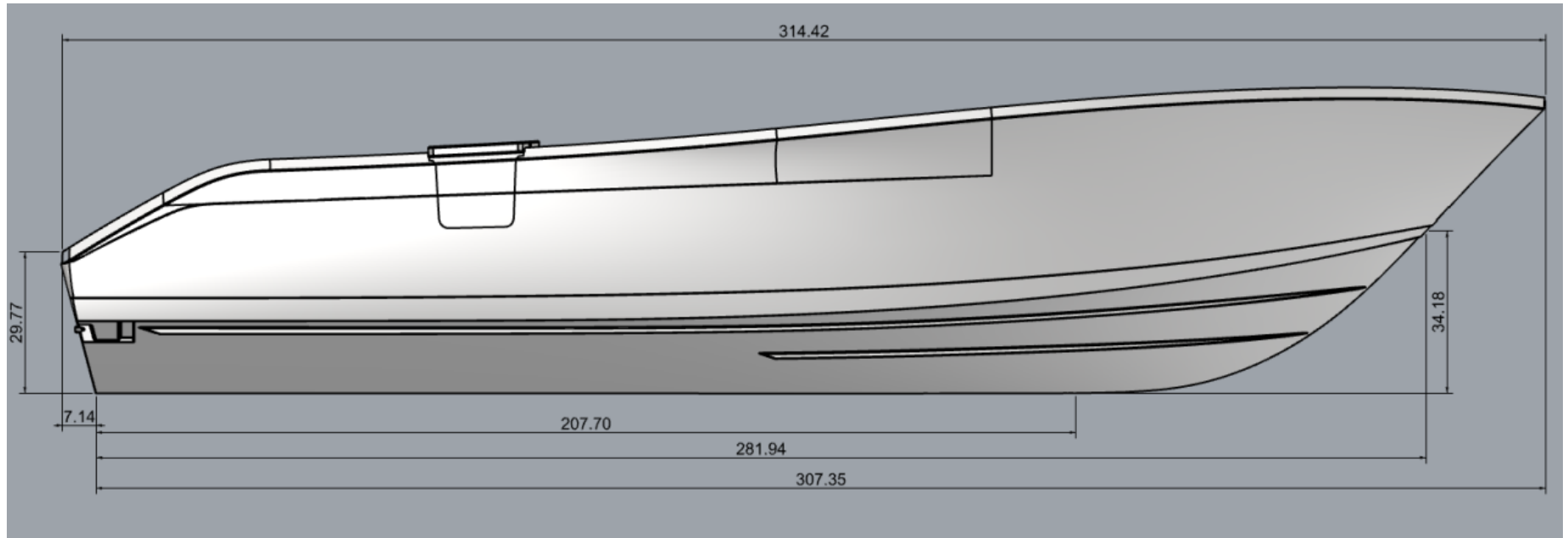

**Maverick Boat Group**  
3207 Industrial 29th St. • Fort Pierce, Florida 34946  
(772)-465-0631 • [cobiaboats.com](http://cobiaboats.com)



**PERMAGUARD®**  
SUPERIOR STAIN RESISTANCE



**PERMAGUARD®** is a newly developed topcoat protective finish that permits frequent cleaning of Spradling's coated fabrics for upholstery. Spradling's proprietary barrier coating makes maintenance easy. Not only do stains disappear in seconds, but **PERMAGUARD** provides unequalled resistance to scratches, scuffs, and abrasion. No other marine vinyl surpasses **PERMAGUARD**'s stain resistance and long-term, trouble-free performance.

**Care & Cleaning Guide**

**For use on the white or the primary seating vinyls only!**  
For cleaning and care of accents and colors, please refer the back of this card.

Remove most stains with one of the following steps:

<b>Step 1</b>	baby oil, ketchup, chocolate, motor oil, olive oil, tea, coffee
<b>Steps 2 &amp; 3</b>	eye shadow, crayon, grease, permanent felt tip marker, mustard, lipstick, ball point pen

**Step 1:** If cleaned immediately, use a clean dry cotton fabric. Wipe once, careful to remove most of the stain without spreading to surrounding area. Wipe more vigorously a second time if residue remains and proceed to step 2.

**Step 2:** If residue remains use a straight application of the following concentrated cleaners:

- *Formula 409®* • *Fantastik®*

Wipe with a clean cloth, rinse with water and dry. If residue remains, proceed to step 3.

**Step 3:** More stubborn soiling may be eliminated using a cotton fabric soaked in 91% isopropyl (rubbing) alcohol. Wipe without spreading stain to surrounding area. A second application should be applied with vigorous rubbing in a circular motion. For highly textured material, a soft toothbrush is recommended to clean valleys and crevices. Wipe with a clean cloth, rinse with water and dry.

Certain clothing and accessory dyes (such as those used on denim jeans) may migrate to lighter colors. This phenomenon is increased by humidity and temperature and is irreversible.

Please check compatibility when using this product in combination with painted or varnished

**Always remove stains immediately. Upholstery must be kept CLEAN!**

Certain household cleaners, powdered abrasives, steel wool, and industrial cleaners can cause damage and discoloration and are not recommended. Dry cleaning fluids and lacquer solvents should not be used as they will remove printed pattern and gloss. Waxes should be used with caution as many contain dyes or solvents that can permanently damage the protective coating.

Suntan lotion, tree pollen, wet leaves, and some other products can contain dyes that stain permanently.

Do not clean with power washers, as they can generate 3500 PSI and could damage the surface of your interior. Do not use kerosene, gasoline, or acetone, as they will remove the protective marine top coat. Do not use any silicone-based protectants. They will extract the plasticizer, leaving vinyl hard and brittle, and eventually cracking will occur.

**Failure to care for your vinyl properly, or use of improper cleaners, may void your warranty & damage your vinyl!**

The information published in this care guide refers to the performance of **PERMAGUARD®** products in specific tests conducted under laboratory conditions. Results may vary under actual conditions.

This information is not a guarantee and does not relieve the user from the responsibility of the proper and safe use of the product and all cleaning agents. The use of certain agents can be harmful to the surface appearance and lifespan of vinyl. Spradling, its agents, and assigns assume no responsibility resulting from the use of such cleaning agents to the vinyl. Spradling's coated fabrics treated with **PERMAGUARD®** protective finish are resistant to most common stains. However existing dyes and pigments in some staining agents have the ability to create a permanent stain if not treated properly.

**PERMAGUARD®** is a trademark of Spradling International, Inc.

©2013 Spradling International, Inc.®

Find more vinyl cleaning & care information at:  
[www.spradlingvinyl.com/sim](http://www.spradlingvinyl.com/sim) or call the cleaning hotline at 1-800-247-9901

America's leading source for vinyl-coated fabrics

**Vinyl Coated Fabrics (Acrylic or Napa Topcoat)**

**Cleaning and Care: Colors and Accent Vinyls**

**Step 1:** For light soiling, a solution of 10% household liquid dish soap in warm water, applied with a soft damp cloth. Rub gently and rinse with a water-dampened cloth.

**Step 2:** For heavy soiling, dampen a soft white cloth with a one-to-one(1:1) solution of \**Formula 409®* and water or \**Fantastik®* and water. Rub gently and rinse with a water-dampened cloth.

**Step 3:** For more difficult stains, dampen a soft white cloth with a solution of household bleach (10% bleach and 90% water). Rub gently and rinse with a water-dampened cloth to remove bleach concentration.

Do not use with alcohol-based cleaning agents!

**All cleaning methods must be followed by a thorough rinse with clean warm water.**

Failure to care for your vinyl properly, or use of improper cleaners, may void your warranty & damage your vinyl!

Certain household cleaners, powdered abrasives, steel wool, and industrial cleaners can cause damage and discoloration and are not recommended. Dry cleaning fluids and lacquer solvents should not be used as they will remove printed pattern and gloss. Waxes should be used with caution as many contain dyes or solvents that can permanently damage the protective coating.

Suntan lotion, tree pollen, wet leaves, and some other products can contain dyes that stain permanently.

Do not clean with power washers, as they can generate 3500 PSI and could damage the surface of your interior. Do not use kerosene, gasoline, or acetone, as they will remove the protective marine top coat. Do not use any silicone-based protectants. They will extract the plasticizer, leaving vinyl hard and brittle, and eventually cracking will occur.

**Always remove stains immediately. Upholstery must be kept CLEAN!**

Please contact our cleaning hotline at 1-800-247-9901 or online at [www.spradlingvinyl.com/sim](http://www.spradlingvinyl.com/sim).

The information published in this care guide refers to the performance of Spradling International Marine products in specific tests conducted under laboratory conditions. Results may vary under actual conditions.

This information is not a guarantee and does not relieve the user from the responsibility of the proper and safe use of the product and all cleaning agents. The use of certain agents can be harmful to the surface appearance and lifespan of vinyl. Spradling, its agents, and assigns assume no responsibility resulting from the use of such cleaning agents to the vinyl. Certain clothing and accessory dyes (such as those used on denim jeans) may migrate to lighter colors. This phenomenon is increased by humidity and temperature and is irreversible.

*Formula 409®* is a registered trademark of the Clorox Company.  
*Fantastik®* is a trademark of DowBrands, Inc.® Trademark of the Dow Chemical Co.®  
*\*Fantastik & Formula 409* are safe to use if cleaner is diluted (1:1), then thoroughly rinsed and used following manufacturers' instructions.

©1997 Spradling International, Inc.®

Please check compatibility when using this product in combination with painted or varnished surfaces.



Find more vinyl cleaning & care information at:  
[www.spradlingvinyl.com/sim](http://www.spradlingvinyl.com/sim) or call the cleaning hotline at 1-800-247-9901

Side A

Side B

3/1/2014



**Maverick Boat Group**  
3207 Industrial 29th St. • Fort Pierce, Florida 34946  
(772)-465-0631 • [cobiaboats.com](http://cobiaboats.com)

# Warranty

Cobia Boats are NMMA Certified and offer superior SeaTech “no wood” construction. All Cobias are backed by a no-nonsense, 10-year limited warranty.

Cobia Boats advises owners that an authorized Cobia Dealer perform maintenance and repairs on your boat. Self repairs and repairs done by a non-authorized Cobia Dealer may void the warranty on the boat. The following information is general in nature and should not be considered a repair manual or guidelines set forth by Maverick Boat Group.

**Cleaning:** Each Cobia Boat is constructed using the finest material and components available. However, no material is immune to the ravages of the saltwater environment. After each use, your boat should be rinsed thoroughly with fresh water. A mild detergent may also be used to remove any dirt, silt or stains. To clean the cushions, use only a damp cloth. Never hose down or saturate the cushions. A light coat of lubricants on metal railing, screws, and electrical connections will help prevent electrolysis. The same holds true for your trailer.

